



# FAILSAFE EMERGENCY BRAKE WORKSHOP MANUAL

## FUSO CANTER FG83



## 1. Revision History

Revision	Issue Date	Author	Comments
1	24 Sep 2018	G. Hainsworth	Initial Release

© Advanced Braking Pty Ltd, 2018.

All rights reserved. No part of this manual may be reproduced in any form or by any means without the prior written consent from the copyright holder. While every attempt is made to ensure that the information in this manual is correct, no liability can be accepted by the authors for loss, damage or injury caused by any errors in, or omissions from, the information given.

## 2. Table of Contents

1.	Revision History .....	2
2.	Table of Contents.....	3
3.	Important Information .....	4
4.	Terminology .....	5
5.	Brake Description .....	6
6.	Important Emergency Brake Information.....	7
7.	Exploded Views & Parts Lists - Differential Brake Assembly .....	9
8.	Wiring Diagram 12V.....	12
9.	Wiring Diagram 24V.....	14
10.	Pump Hardware Parts List 12V .....	16
11.	Pump Hardware Parts List 24V .....	18
12.	Installation – Driveline Brake (Light - Medium Trucks).....	20
13.	Installation – Hydraulic System .....	23
14.	Installation – Electrical System .....	25
15.	Pre-Service Inspection .....	29
16.	Control System Setup .....	32
17.	Service Schedule .....	33
18.	Pre-Start Check .....	34
19.	Minor Service (100 hrs) .....	35
20.	Major Service .....	37
21.	EMMA Piston Test Procedure .....	38
22.	Service Disassembly Procedure .....	39
23.	Rotor Replacement Procedure .....	40
24.	Pad Change, Seal Change and Housing Inspection .....	41
25.	Spring Replacement Procedure .....	42
26.	EMMA Piston and Piston Seal Replacement Procedure .....	44
27.	Service Assembly and Bleed Procedure.....	45
28.	Troubleshooting.....	48

### 3. Important Information

This manual applies to the fourth generation ABT™ Failsafe Emergency brake for Fuso Canter 4x4 Trucks. The manual details how to install the brake system correctly to ensure optimum safety and performance. All information contained in this manual is based on the latest ABT™ Failsafe Emergency product information available at the time of publication.

This manual should be read in conjunction with the appropriate Fuso Canter vehicle manual for further information on removal and installation of any standard Mitsubishi/Fuso components.

While every effort has been made to address all aspects of installation and servicing, please advise Advanced Braking of any omissions or suggestions on how this manual may be improved.

Advanced Braking Pty Ltd reserves the right to change the manual at any time without prior notice.

The most up to date version of the manual can be obtained by contacting the ABT™ Customer Service Manager.

The ABT™ and EMMA™ trademarks are owned by Advanced Braking Pty Ltd.



Street Address:      Advanced Braking Pty Ltd  
                                 19 Creative Street  
                                 Wangara WA 6065  
                                 AUSTRALIA

Postal address:      19 Creative Street  
                                 Wangara WA 6065  
                                 AUSTRALIA

E-mail:                    sales@advancedbraking.com

Website:                www.advancedbraking.com

Phone:                    +61 (08) 9302 1922

## 4. Terminology

<b>ATF</b>	Automatic transmission fluid
<b>DPS</b>	Door proximity system
<b>Driveline Brake</b>	Single brake unit acting on the rear axle differential
<b>Emergency Brake</b>	Brakes automatically applied in an emergency
<b>EMMA™</b>	Electronically Modulated Mechanically Applied
<b>OEM</b>	Original equipment manufacturer
<b>Park Brake</b>	Brakes applied independently of the service brake
<b>PWI</b>	Pad wear indicator
<b>SAHR</b>	Spring Applied Hydraulic Release
<b>ABT™ Failsafe Emergency</b>	Differential mounted fully sealed brake with SAHR
<b>ABT™ "Blend 20"</b>	Specially formulated cooling fluid for use in ABT™ Failsafe and Failsafe Emergency brakes

## 5. Brake Description

The ABT™ Failsafe Emergency brake is a Spring Applied Hydraulic Release system operating in isolation from any other braking system fitted to the vehicle. It has been configured for mounting to the driveline of light trucks through to heavy goods vehicles. The brake is bolted to the input side of the rear differential carrier. The torque generated by the brake is transmitted to the rear wheels via the differential and axle shafts.

The ABT™ Failsafe Emergency brake operates as a spring applied hydraulic release emergency driveline brake only. The hydraulic system has been designed to modulate the application preventing shock loads damaging the driveline.

ABT™ Failsafe Emergency is an enclosed single rotor high-speed disc brake. It provides greater reliability in a compact enclosed package. The brake is designed for harsh mining environments and can be submerged for short periods without affecting operation.

## 6. Important Emergency Brake Information

1. The brake is intended as an emergency brake only for use in the event of a service brake system failure. The system is not designed as an additional service brake.
2. Do not perform dynamic stops unless in an emergency situation. If the brake is used in an emergency situation it is recommended to strip and inspect the brake and diff components.
3. The ABT™ Failsafe Emergency driveline brake is not designed as a vehicle retarder and should only be used in the case of an emergency.
4. *The ABT™ Failsafe Emergency Driveline Brake System LV21 is designed for “off highway” use. Whilst it is possible to operate the vehicle with the brake attached at highway speeds without damage, unintended application of the brake will rapidly and effectively arrest the vehicle. ABT™ recommends that the brake is disabled for highway use or when the vehicle is to be driven above speeds of 60kph by installing the supplied retractor bolts. This recommendation applies to delivery of the vehicle to site and any other extended “on highway” or “above speeds of 60kph” use.*

### WARNING:



Before operating the vehicle on a mine site, the retractor bolts **MUST** be removed and replaced with plugs and pad wear indicator. Power to the control box **MUST** be restored.

### NOTE:

Ensure the ABT™ Failsafe caution and warning labels are attached to a prominent position on the windshield. Refer Section 15.

### NOTE:

Ensure the Control Box Tag is attached to the Control Box if the brake has been made inoperable due to the fitment of retractor bolts. While retractor bolts are fitted the Failsafe Emergency control system must be made inoperable by disconnecting the control box on the dash or by removing the main fuses from the battery power harness.

This page has been left blank intentionally.



## 7. Exploded Views & Parts Lists - Differential Brake Assembly

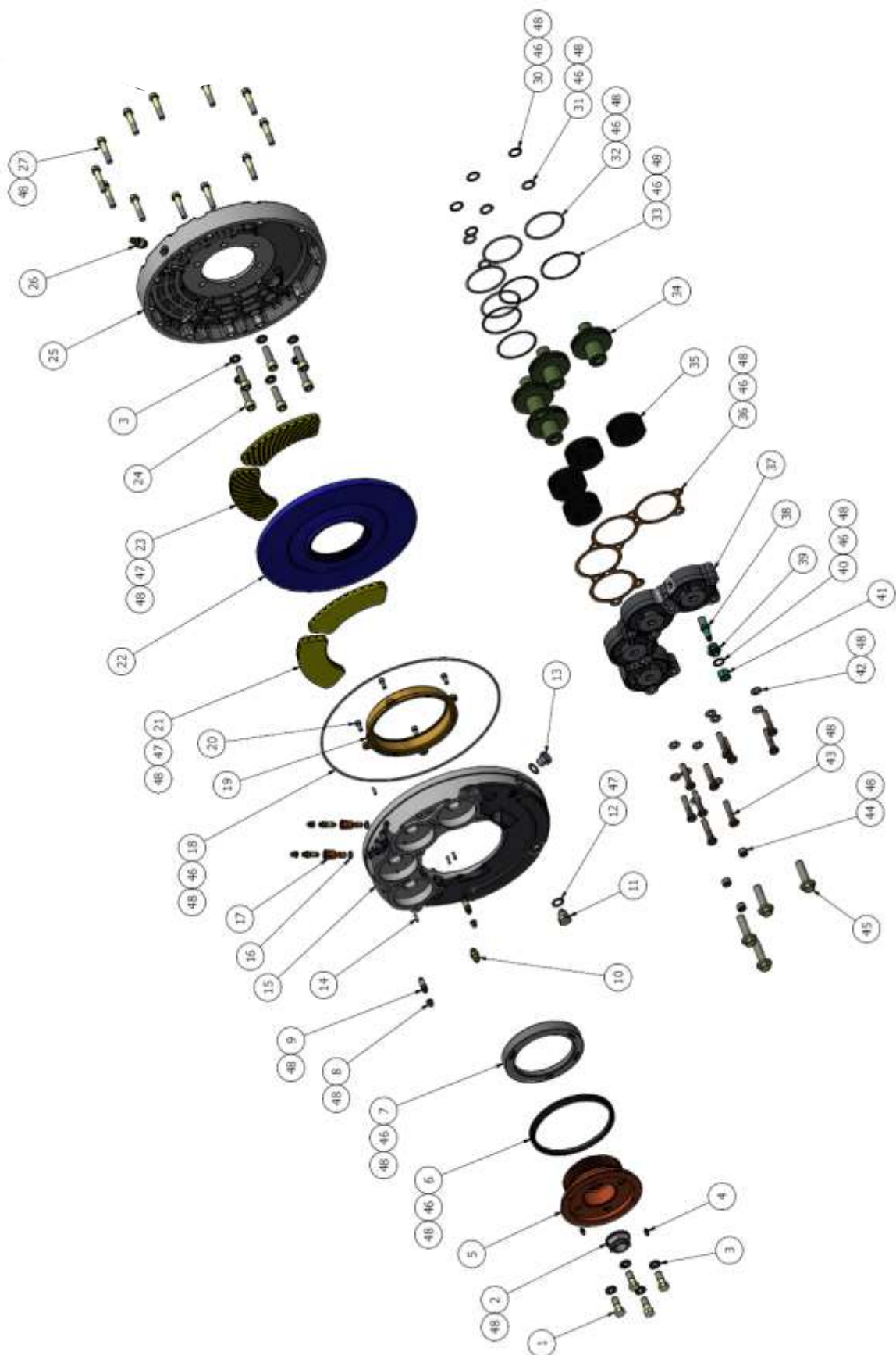

ITEM	PART NO.	DESCRIPTION	QTY/ BRAKE	TORQUE (Nm)
1	21-9008	BOLT DRIVE SHAFT	4	130
2	OEM	NUT PINION (OEM)	1	Ref. Canter manual
3	21-9009	WASHER DRIVE SHAFT	10	-
4	31-5015	NIPPLE GREASE	2	5
5	21-2011	YOKE LV21	1	-
6	31-4013	SEAL V-LIP	1	-
7	25-2049	SEAL CASSETTE HOUSING	1	-
8	31-9000	CAP BLEED NIPPLE	4	-
9	31-5001	BLEED NIPPLE	4	15
10	31-5000	CONNECTOR HOSE EMMA	1	20
11	25-2039	PLUG DRAIN	1	20
12	30-2003	WASHER SEALING COPPER	2	-
13	31-5035	PLUG FILL	1	20
14	31-3001	PIN DOWEL	4	-
15	21-2001	HOUSING OUTER	1	-
16	31-2004	WASHER SEALING COPPER	2	-
17	21-2006	ADAPTER BLEED NIPPLE	2	20
18	31-2006	O-RING HOUSING	1	-
19	21-2005	CARRIER HOUSING SEAL	1	-
20	30-0059	BOLT SEAL CARRIER	4	10
21	25-4030	BRAKE PAD OUTER	2	-
22	25-2000	BRAKE ROTOR	1	-
23	25-4029	BRAKE PAD INNER	2	-
24	30-0108	BOLT BRAKE MOUNTING	6	100
25	21-2008	HOUSING INNER	1	-
26	31-5032	CONNECTOR BARB BREATHER HOSE	1	15
27	30-0003	BOLT BRAKE HOUSING	12	50

30	31-2001	BACK-UP WASHER SMALL EMMA PISTON	4	-
31	31-2000	O-RING SMALL EMMA PISTON	4	-
32	31-2002	O-RING LARGE EMMA PISTON	4	-
33	31-2003	BACK-UP WASHER LARGE EMMA PISTON	4	-
34	25-2006	PISTON EMMA	4	-
35	31-0002	DISC SPRING	24	-
36	25-2061	SPRING COVER GASKET	1	-
37	25-2008	COVER SPRING EMMA	1	-
38	25-2040	PLUNGER PAD WEAR INDICATOR	1	15
39	25-2041	PLUG PAD WEAR INDICATOR	1	15
40	30-2005	WASHER PAD WEAR INDICATOR	1	-
41	25-2042	CAP PAD WEAR INDICATOR	1	10
42	30-2000	WASHER FLAT SPRING COVER	10	-
43	30-0001	SPRING COVER BOLT	10	60
44	31-5004	PLUG SPRING COVER	3	10
45	30-0028	RETRACTOR BOLT	4	80
46	21-5000	KIT SEAL	1	-
47	25-5047	KIT BRAKE PAD	1	-
48	21-5001	KIT MAJOR SERVICE	1	-

# 8. Wiring Diagram 12V

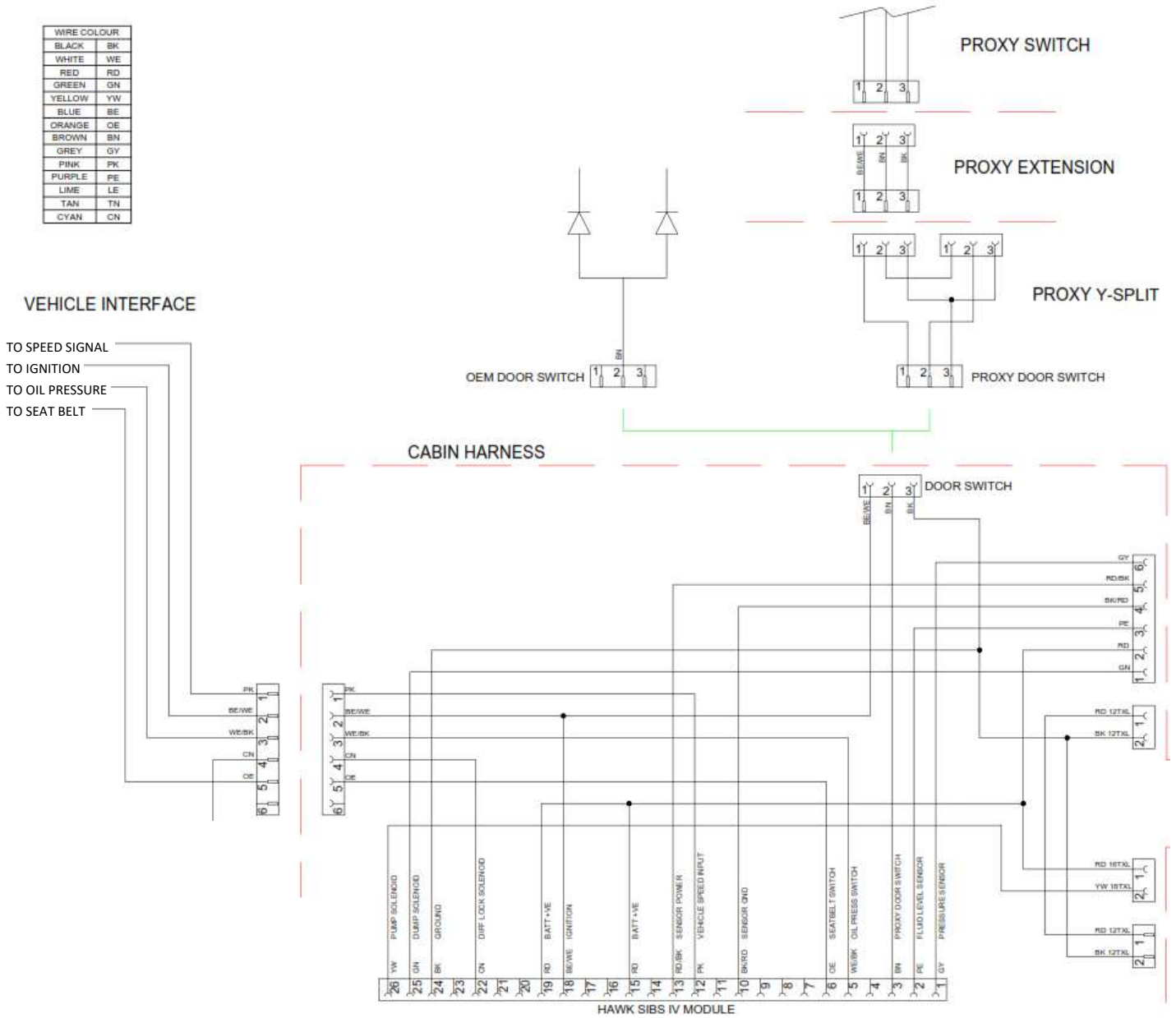

### PUMP ENCLOSURE LOOM

#### CAB TO PUMP EXTENSION

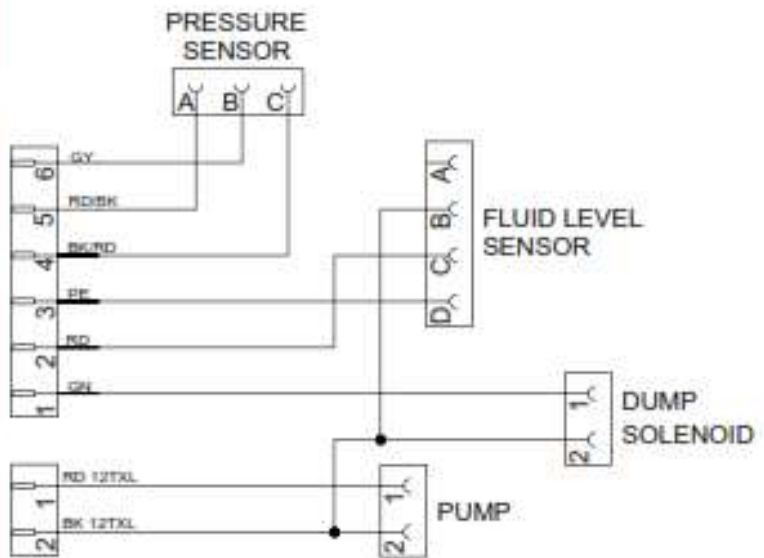
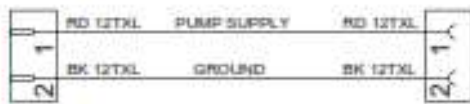
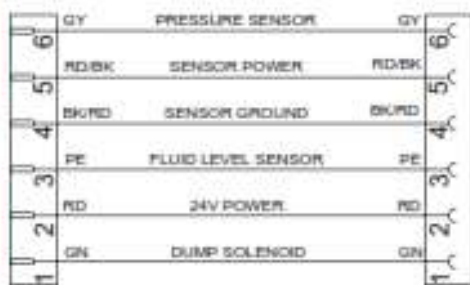

#### ENGINE BAY HARNESS

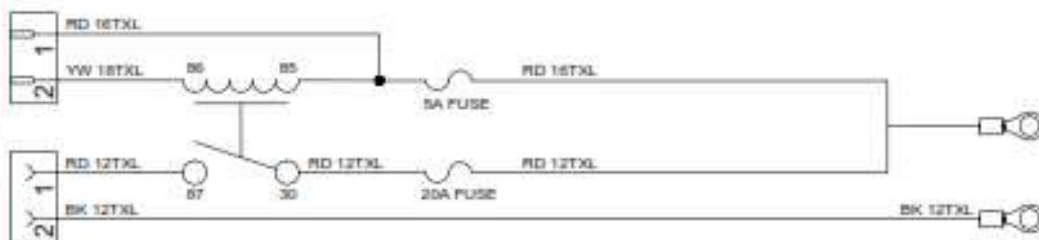

# 9. Wiring Diagram 24V

WIRE COLOUR	
BLACK	BK
WHITE	WE
RED	RD
GREEN	GN
YELLOW	YW
BLUE	BE
ORANGE	OE
BROWN	BN
GREY	GY
PINK	PK
PURPLE	PE
LIME	LE
TAN	TN
CYAN	CN

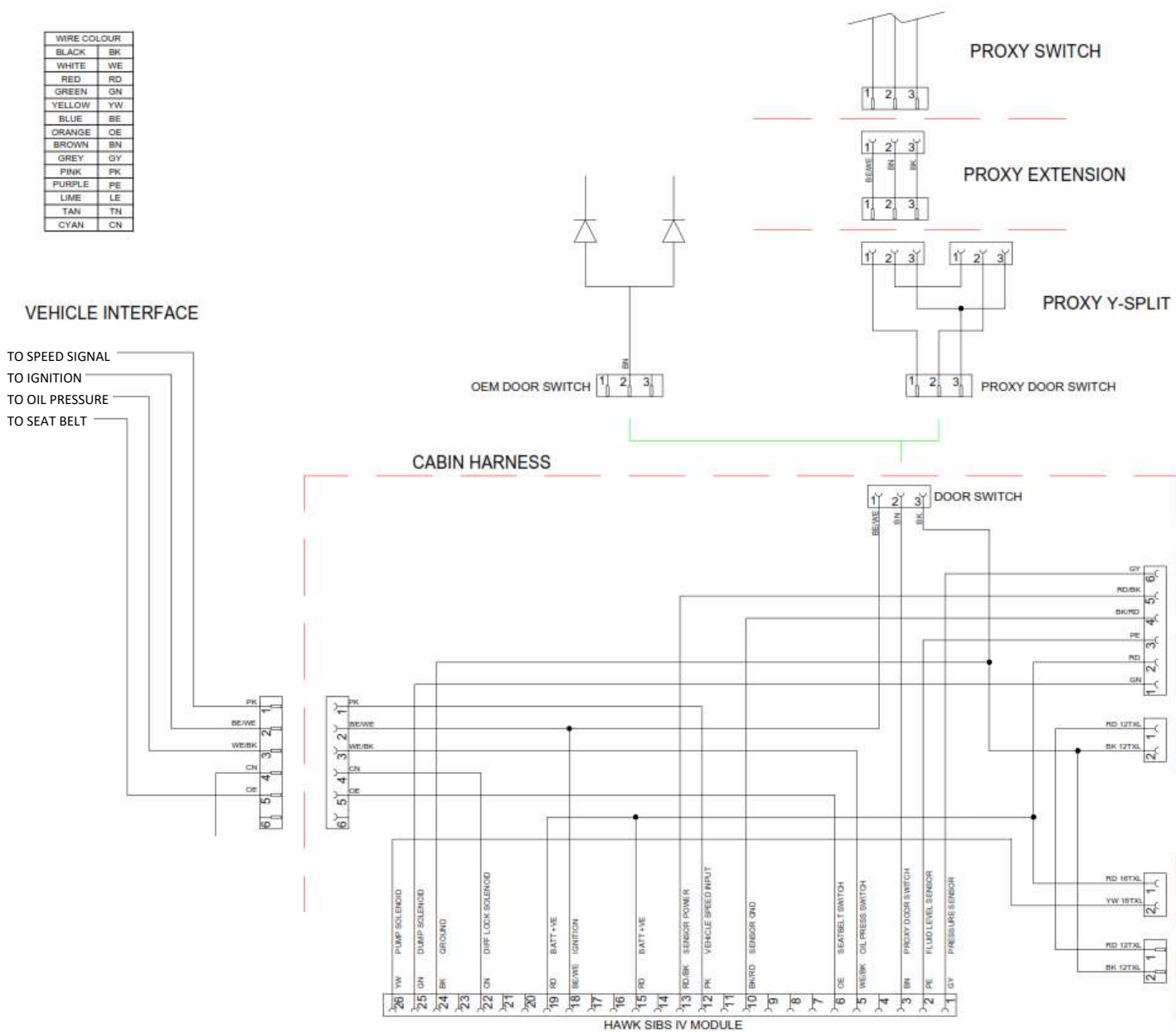

**PUMP ENCLOSURE LOOM**

**CAB TO PUMP EXTENSION**

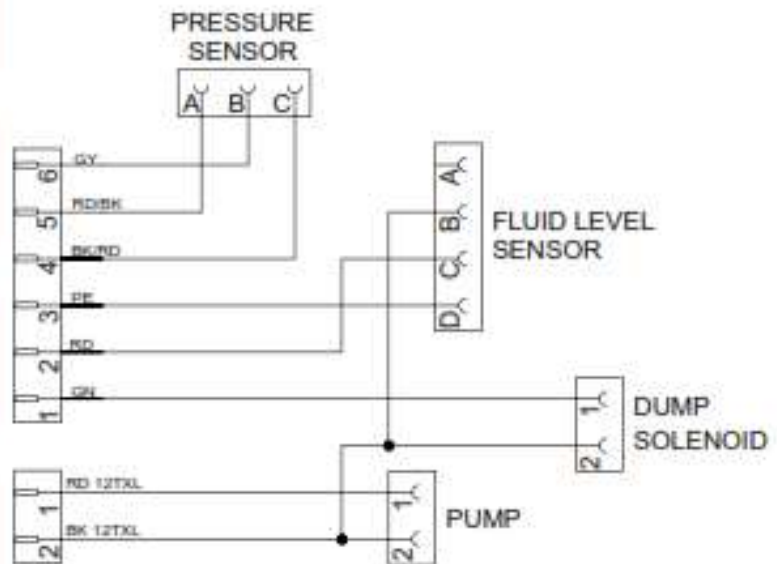

**ENGINE BAY HARNESS**

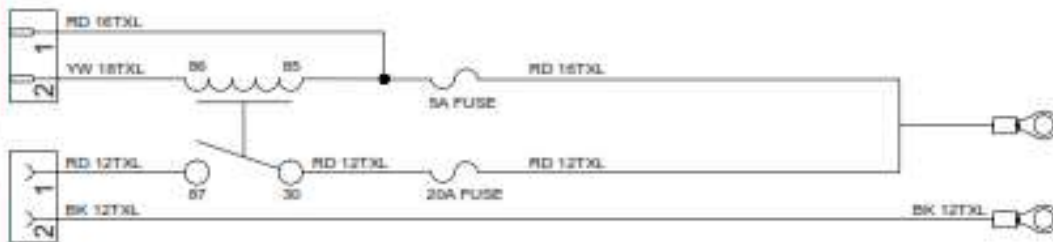

### 10. Pump Hardware Parts List 12V

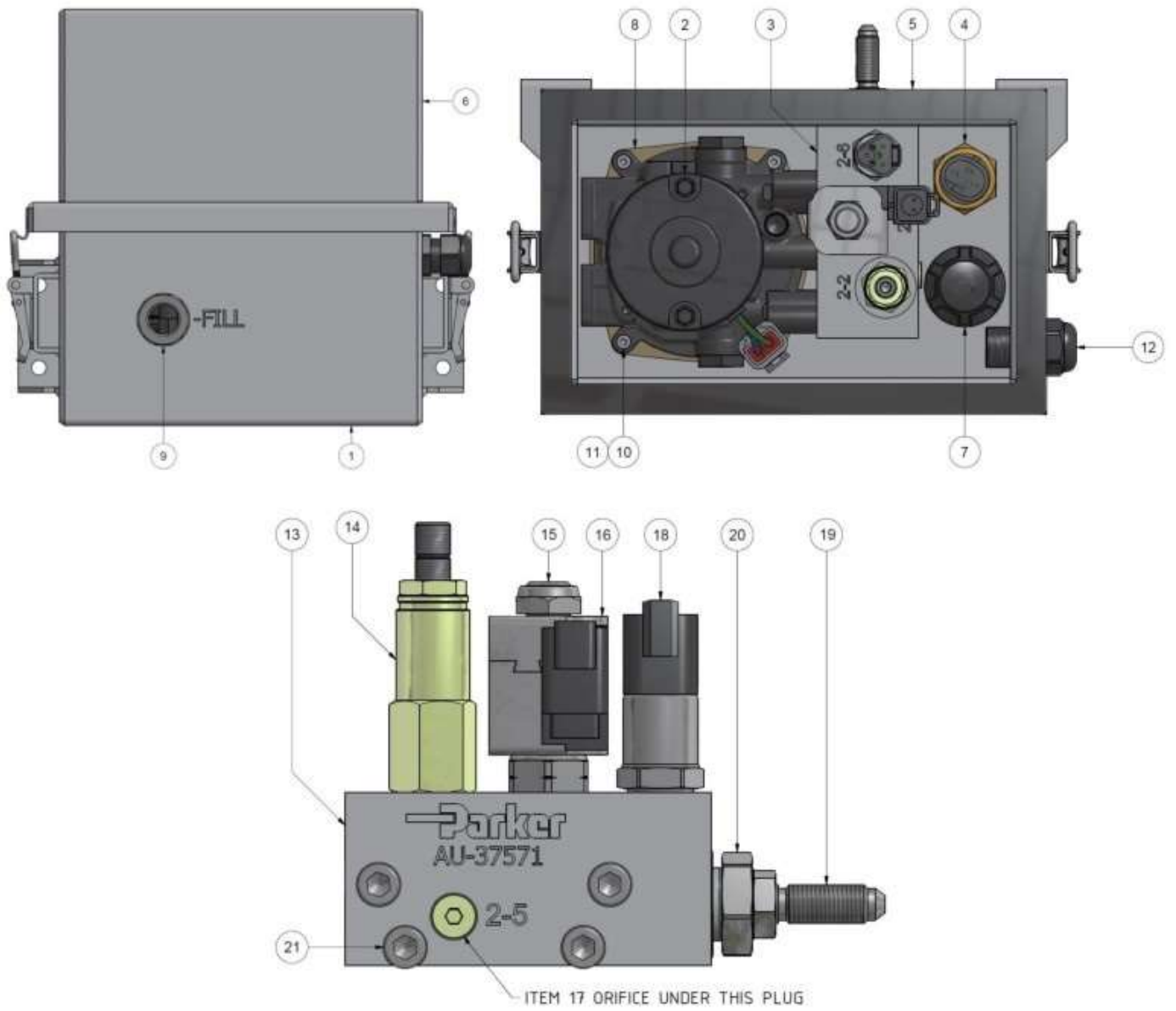



ITEM	PART NO.	DESCRIPTION	QTY/KIT
1	18-9015	ENCLOSURE BASE/RESERVOIR	1
2	18-9018	MOTOR ELECTRIC 12V	1
3	18-9014	MANIFOLD ASSEMBLY 12V	1
4	18-9027	LEVEL SENSOR	1
5	18-9028	ENCLOSURE GASKET	1
6	18-9028	ENCLOSURE LID	1
7	18-9024	FILL CAP	1
8	18-9029	POWER UNIT GASKET	1
9	18-9030	LEVEL WINDOW	1
10	18-9031	SCREW POWER UNIT	4
11	18-9032	WASHER SPRING POWER UNIT	4
12	18-9033	CABLE GLAND	1
13	18-9034	MANIFOLD BLOCK	1
14	18-9035	RELIEF VALVE	1
15	18-9036	SOLENOID VALVE	1
16	18-9021	COIL 12V	1
17	18-9037	ORIFICE 0.5mm	1
18	18-9017	PRESSURE SENSOR	1
19	18-9038	BULKHEAD FITTING	1
20	18-9039	ADAPTER FITTING MANIFOLD TO BULKHEAD	1
21	18-9040	SCREW MANIFOLD BLOCK	4
22	18-4033	MANIFOLD O-RING SEAL KIT	1

### 11. Pump Hardware Parts List 24V

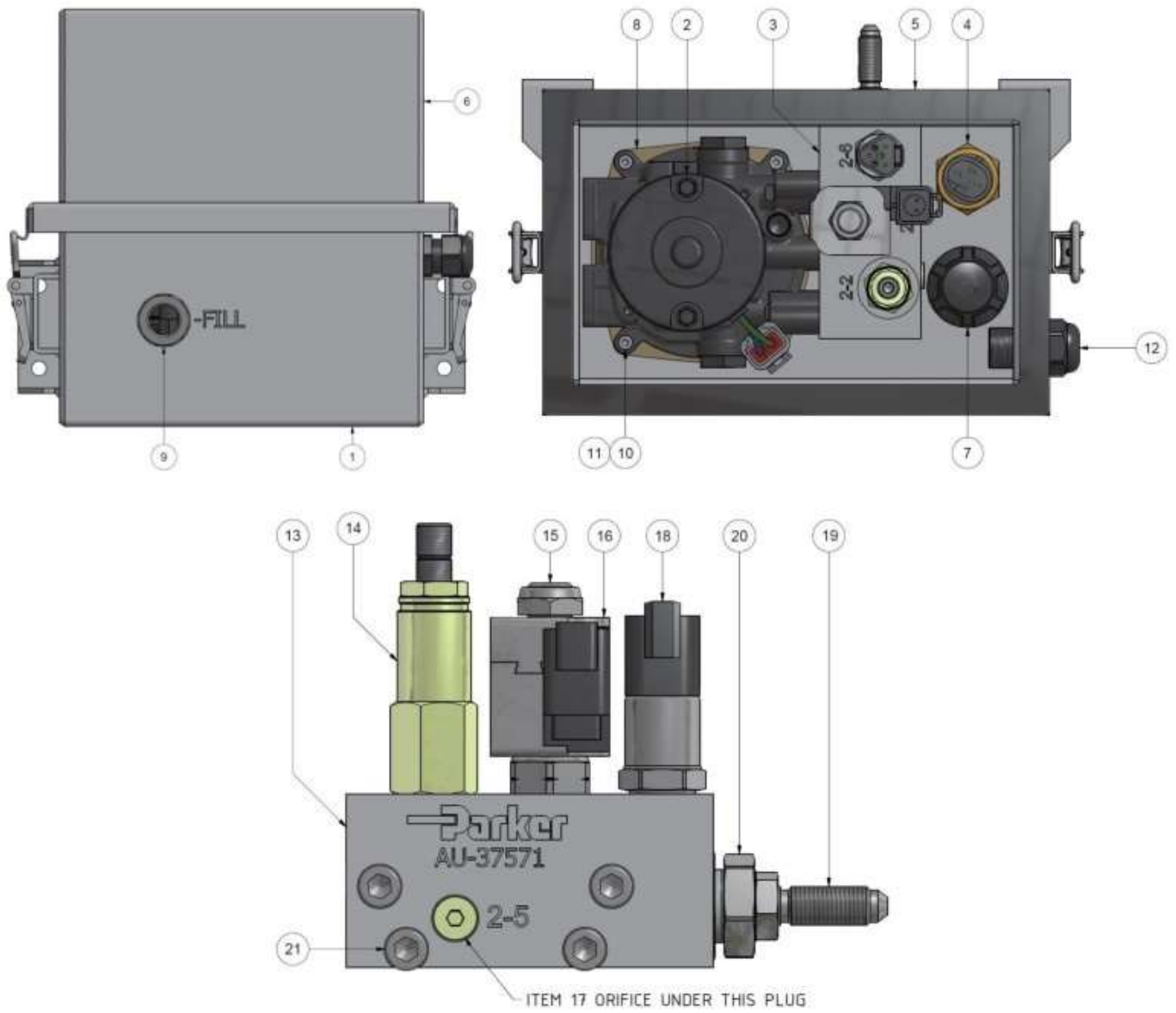

ITEM	PART NO.	DESCRIPTION	QTY/KIT
1	18-9015	ENCLOSURE BASE/RESERVOIR	1
2	18-9019	MOTOR ELECTRIC 24V	1
3	18-9025	MANIFOLD ASSEMBLY 24V	1
4	18-9027	LEVEL SENSOR	1
5	18-9028	ENCLOSURE GASKET	1
6	18-9028	ENCLOSURE LID	1
7	18-9024	FILL CAP	1
8	18-9029	POWER UNIT GASKET	1
9	18-9030	LEVEL WINDOW	1
10	18-9031	SCREW POWER UNIT	4
11	18-9032	WASHER SPRING POWER UNIT	4
12	18-9033	CABLE GLAND	1
13	18-9034	MANIFOLD BLOCK	1
14	18-9035	RELIEF VALVE	1
15	18-9036	SOLENOID VALVE	1
16	18-9022	COIL 24V	1
17	18-9037	ORIFICE 0.5mm	1
18	18-9017	PRESSURE SENSOR	1
19	18-9038	BULKHEAD FITTING	1
20	18-9039	ADAPTER FITTING MANIFOLD TO BULKHEAD	1
21	18-9040	SCREW MANIFOLD BLOCK	4
22	18-4033	MANIFOLD O-RING SEAL KIT	1

## 12. Installation – Driveline Brake (Light - Medium Trucks)

1. The ABT™ Failsafe Emergency driveline brake is installed on the forward side of rear differential carrier.
2. Drain and keep enough diff oil from the rear differential carrier to prevent spillage as the pinion bearing cage will be removed for Failsafe Emergency brake installation.
3. Remove drive shaft from rear yoke. The drive shaft may be removed completely if desired.
4. Remove the yoke from the pinion shaft.
5. Remove the pinion bearing cage and retain any shims for later use. Ensure no dirt ingress into the diff centre.
6. Remove and keep the bearing rollers. Remove and discard pinion seal.
7. Attach Wittenbaker Engineering Services bracket as per Wittenbaker Engineering Services installation instructions
8. Apply Loctite 515 between Wittenbaker Engineering Services bracket mounting face and the Failsafe Emergency inner brake housing. Note: in some cases, a mounting adapter is required between the bearing cage and the inner housing. If required apply Loctite 515 to both sides.
9. Attach the inner housing with the brake pads positioned to the top of the brake.
10. Attach the mounting bolts and washers. Torque to 100Nm. Repeat 3 times over 5 minutes.
11. Ensure the housing O-ring is attached to the outer brake housing.
12. Ensure the brake pads are in position on the inner brake housing.



Figure 1: Diff centre with inner housing attached.

13. Attach the V-seal to the yoke.
14. The preassembled outer housing should be attached to the yoke and rotor. Ensure brake pads are attached to the outer housing.

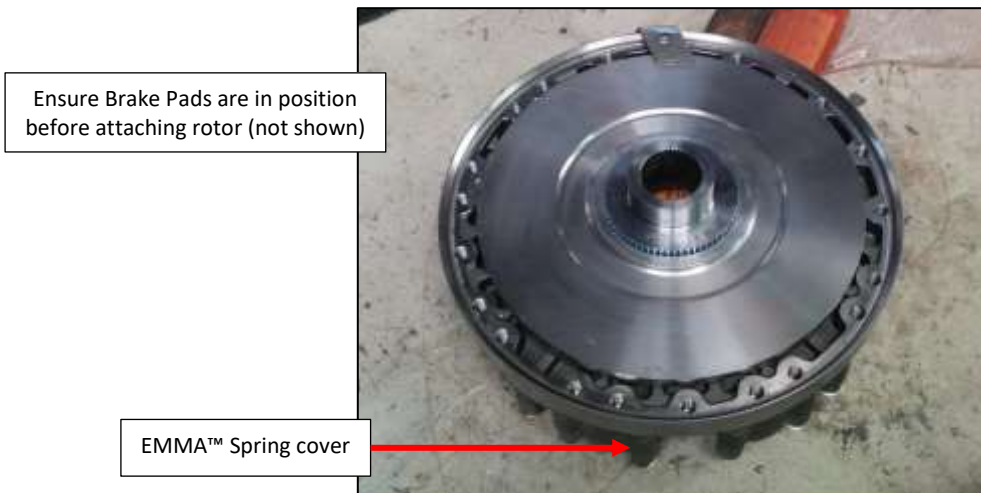

Figure 2: Outer housing, yoke and rotor assembly.

15. Attach the outer housing, yoke and rotor to the inner brake housing. Use of a jack or lifting table is recommended to assist with lifting the assembly into position.
16. Hold the brake rotor to prevent it from detaching from the yoke during assembly.
17. Lift outer assembly and align the yoke with the pinion shaft with the EMMA™ spring covers positioned towards the bottom of the brake.
18. Once the brake is held by the pinion shaft, rotate the outer housing until the EMMA™ spring covers are positioned towards the top of the brake.
19. Align the dowel pins before attaching the housing bolts.
20. Fit the 12x M10 bolts and torque to 50Nm in sequence. Ensure each bolt is torqued twice.
21. Attach the 2x grease nipples to the yoke.
22. Attach the pinion shaft nut. Set preload and torque as per Fuso Canter Manual.
23. Ensure the diff rotates freely when the ABT™ Failsafe Emergency brake is released.



Figure 3: Brake mounted in position on the forward side of the rear diff centre.

24. Assemble the drive shaft onto the ABT™ yoke. Torque fasteners to 130Nm.
25. Complete the hydraulic and electrical installations as per sections 13 and 14 of this manual.

26. Fit the Expansion chamber:
- Mount the expansion chamber as high as possible in a protected location on the vehicle. ABT™ recommends mounting to the chassis cross-member.
  - Secure using the supplied mounting hardware.
  - Run a length of breather hose between the expansion chamber and the brake unit.
  - Route the hose away from the exhaust and any moving components. Allow extra length for axle articulation.
  - Protect areas of the hose that may abrade using spiral guard.
  - Ensure ABT™ “Blend 20” fluid can easily drain back into the brake units.
  - Secure the hose using supplied P-clips.

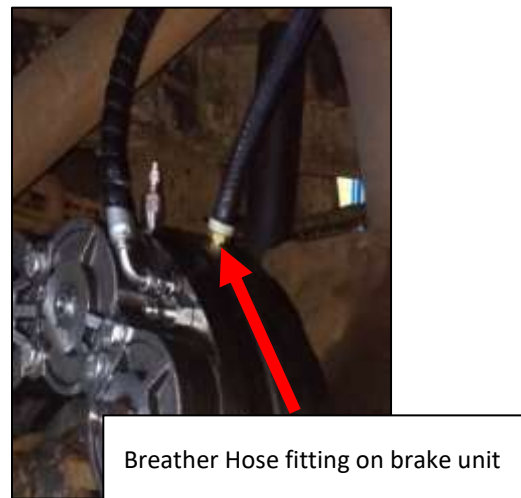
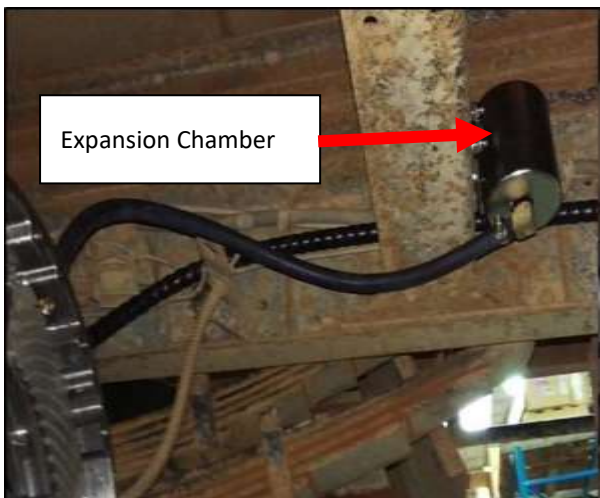

Figure 4: Brake Expansion Chamber and breather hose.

### 13. Installation – Hydraulic System

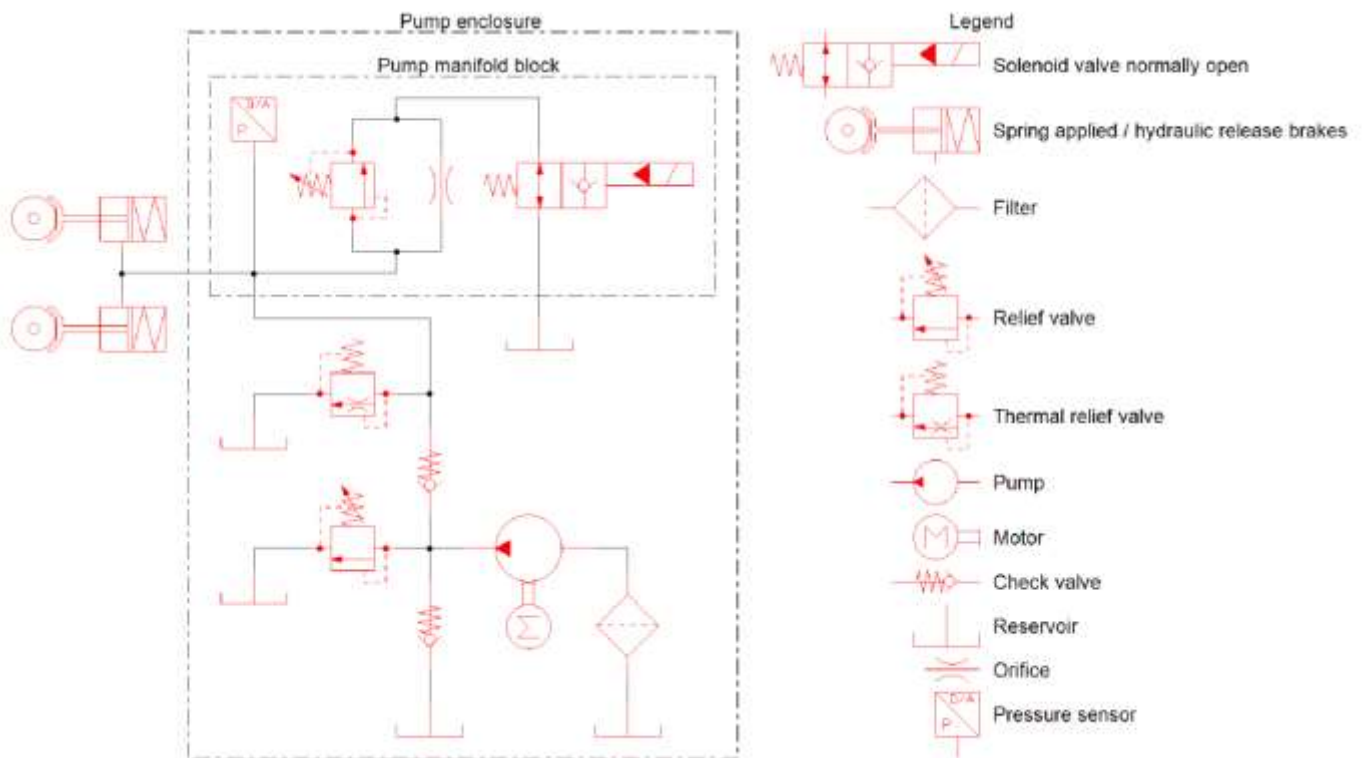

Figure 5: ABT™ Failsafe Hydraulic Schematic.

1. Mount the ABT™ pump enclosure in a suitable location on the vehicle chassis as close to the battery as possible.
2. Drill the pump mounting bracket as required and mount the ABT™ pump using provided mounting hardware.



Figure 6: ABT™ Failsafe Emergency brake pump enclosure.

3. Connect one end of the short park/emergency brake hydraulic hose to the bulkhead fitting at the rear of the pump enclosure.



Figure 7: Hydraulic connections.

4. Attach bulkhead fitting to the vehicle chassis rail behind the pump enclosure.
5. Attach the other end of the short hydraulic hose to this bulkhead fitting on the outside of the vehicle chassis.
6. Attach one end of the long hydraulic hose to the bulkhead fitting on the inside of the chassis rail.
7. Route the other end of the hydraulic hose down along the chassis rail to the brake on the rear diff centre and connect. Secure the hose along the chassis using supplied P-clips.

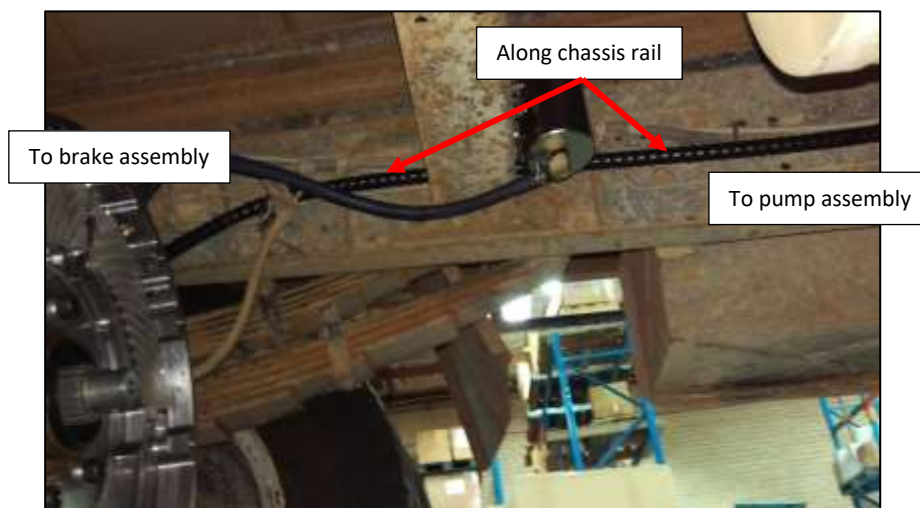

Figure 8: Hydraulic hose routing to brake.

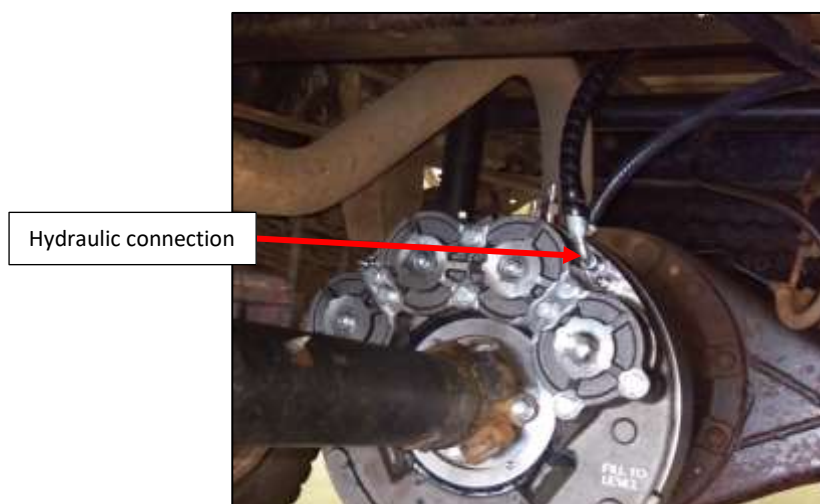

Figure 9: Hydraulic connection to brake.



## 14. Installation – Electrical System

1. Isolate the vehicle battery.

**NOTE:**

Do not test the control system functions until the system is fully installed as this may confuse the control unit while learning – details on control unit setup can be found in Section 16.

2. Mount the control unit to the dash:
  - a. Mount the ABT™ control unit on the dash above the centre console using the provided bracket. Position so that bracket is close to the driver and aligned with the vehicle axis. 4x holes will need to be drilled.
  - b. For LH drive vehicles the control unit bracket can be reversed so that it is always facing the vehicle operator.

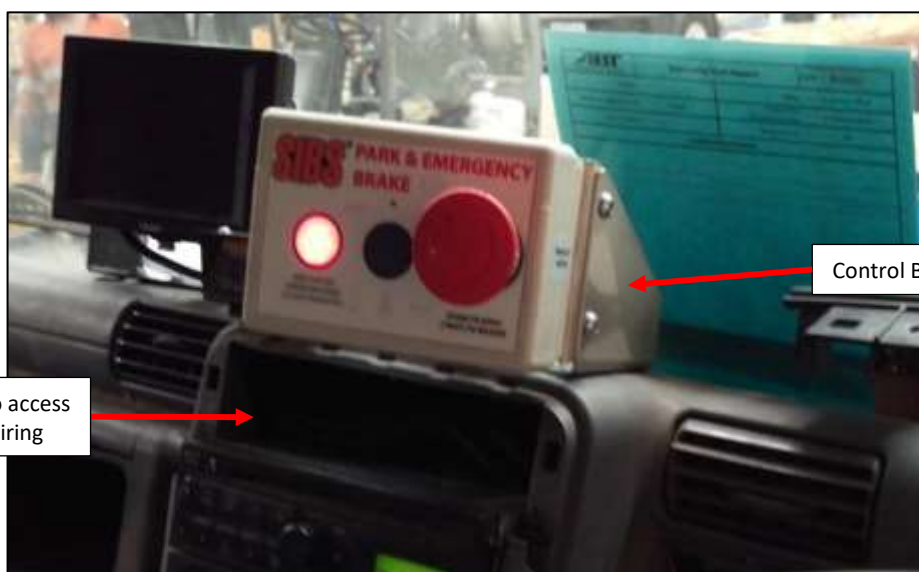

Figure 10: ABT™ Failsafe Emergency brake control unit mounted on dash.

3. Fit the ABT™ cabin harness 18-7012:

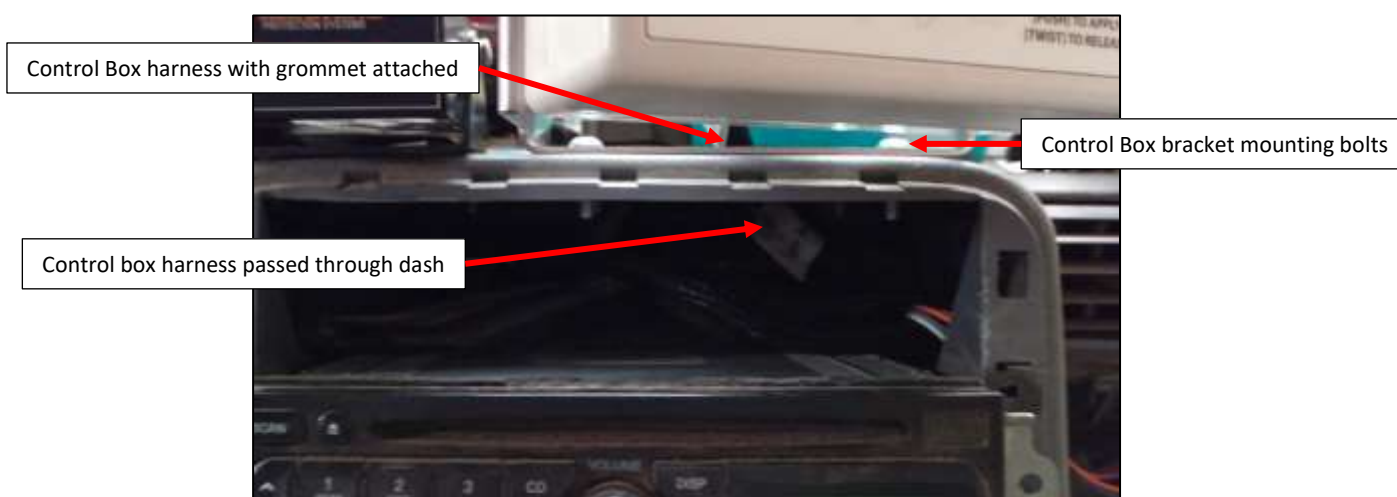

Figure 11: Control unit wiring.

- a. Connect cabin harness branch to the rear of the control unit by passing up through the dash. A hole will need to be drilled in the dash to achieve this.
- b. It may be easier to route the cabin harness with 2 of the Deutsch connectors de-pinned. Note the pin location.

- i. Locate the connectors for the battery power and relay, approximately 2 metres from the end of the harness.
  - ii. De-pin both the 2 pin connector plug with the red and yellow cables attached and the large 2 pin connector socket next to it.
- c. Remove the glove box and the panel from in front of the passenger seat.
  - d. Route the harness down behind the glove box until it drops out underneath on the floor.

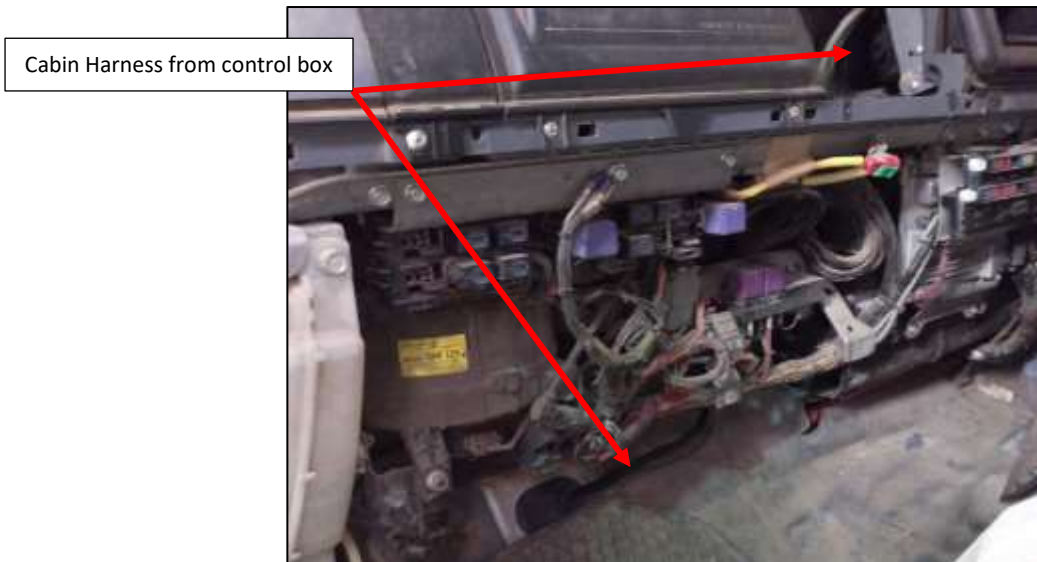

Figure 12: Cabin harness routing.

- e. Push the harness out through an existing rubber boot located at the front of the foot well in front of the passenger seat.
- f. Secure the harness where necessary using cable ties.
- g. Re-pin the connectors. Pin to the previously noted orientation.
- h. Route the harness along the underside of the cab towards the chassis rail.
- i. Route the harness back along the chassis rail towards the vehicle battery. Secure with p-clips where necessary.
- j. Use extension harnesses provided if required.
- k. Secure the harnesses where necessary with p-clips or cable ties.

4. Fit the vehicle interface harness:
  - a. Open the top of the dash above the centre console.
  - b. Connect the Deutsch end of the vehicle interface harness to the 6 pin connector on the ABT™ cabin harness.
  - c. Connect the interface harness wires to the desired vehicle interlock wires behind the instrument cluster. Cut the wires to the desired length.
  - d. De-pin any unwanted wires from the interface harness.

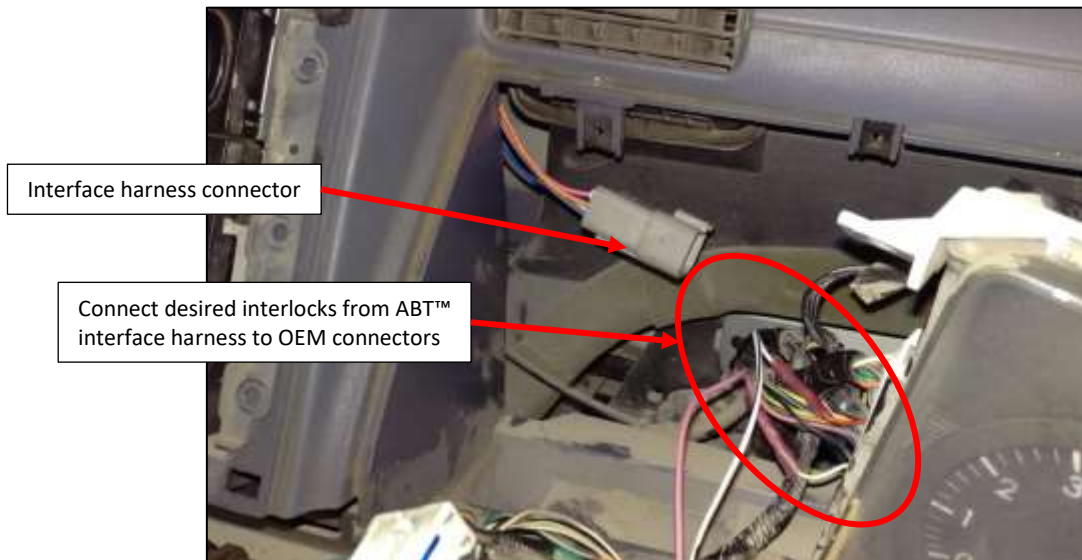

Figure 13: Connection for interlocks behind the instrument cluster.

5. Fit the OEM door harness 18-7008 (optional):
  - a. The OEM door harness is supplied with the vehicle interface harness – simply connect the additional 3-pin Deutsch connector to the ABT™ cabin harness located in the dash under the control box.
  - b. Do not connect if ABT™ door proximity sensors are to be fitted.

6. Fit the Battery power harness:

- a. Extension harnesses may be required depending on vehicle battery location. If not required connect the cabin harness directly to the battery power harness and move to section 'd'.
- b. Connect the battery power extension harness to the 2x 2 pin connectors on the cabin harness located on the chassis rail.
- c. Route the battery power extension harness towards the vehicle battery.
- d. Connect the battery power extension harness to the battery power harness.



Figure 14: Battery power harness.

- e. Connect the red wires to the positive battery terminal via the eyelet.
  - f. Connect the black wire to a vehicle earth point via the eyelet.
  - g. Secure the harness where necessary using P-clips or cable ties.
7. Connect to the Pump harness:
- a. Extension harnesses may be required depending on EMMA™ pump assembly location. If not required connect the cabin harness directly to the pump harness.

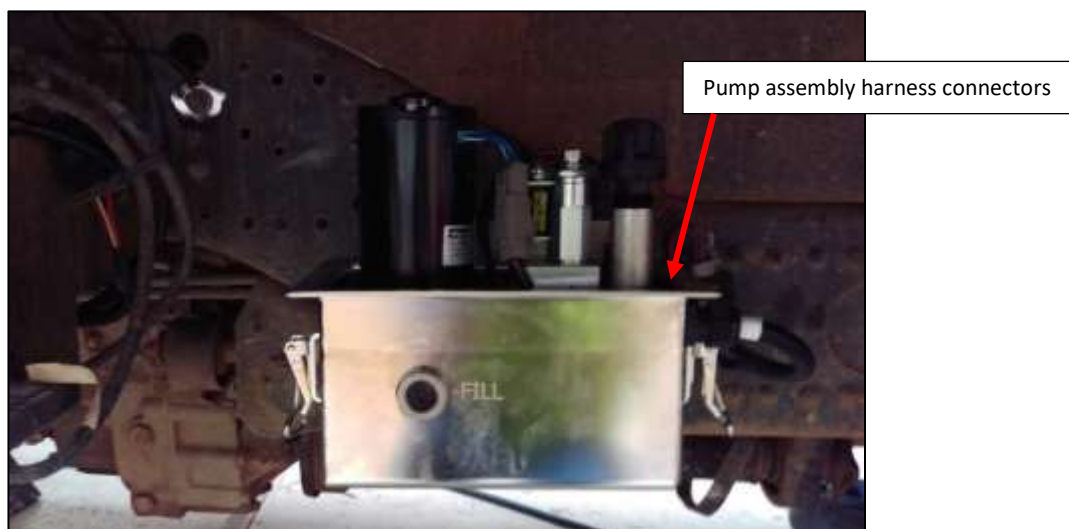

Figure 15: Pump harness connection.

- b. Secure the harness where necessary using P-clips.

## 15. Pre-Service Inspection

1. Top up all reservoirs with the specified fluids.
  - a. Use ABT™ “Blend 20” cooling fluid for the brake. 800ml approx. required.
  - b. Use ATF Dexron III for the ABT™ Failsafe Emergency pump reservoir.

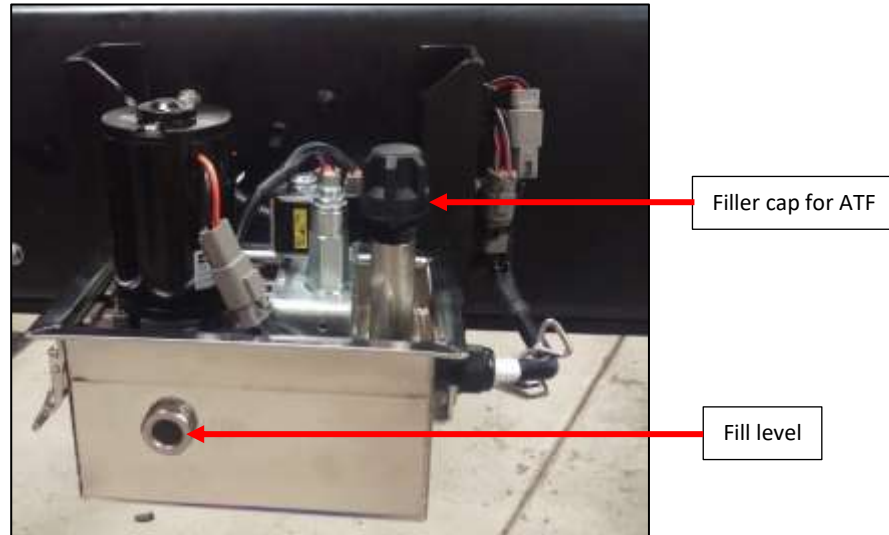

Figure 16: ABT™ Failsafe Emergency brake pump enclosure with lid removed.

2. Ensure the battery is in good condition – this is critical to ensure correct programming of the control unit.
3. Reconnect the vehicle battery to power the vehicle and ABT™ Failsafe Emergency system.
4. Bleed the ABT™ Failsafe Emergency brake system:
  - a. Twist and release the red E-stop button on the control unit.
  - b. If the control system detects air in the system on first release, it will enter bleed mode – this is indicated by the brake status light flashing green – system pressure will be limited to 100 psi.
  - c. With the E-stop released, thoroughly bleed the brake system by opening and closing the driveline brake system bleed nipples until the fluid runs through clearly with no air bubbles. Ensure the pump reservoir is topped up regularly during the procedure.
  - d. Once the system is bled, while the E-stop is still released, remove the retractor bolts.

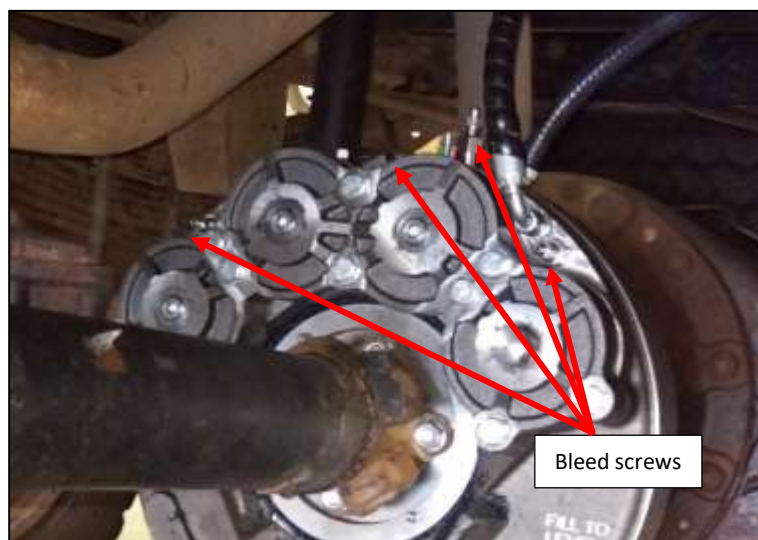

Figure 17: Failsafe Emergency brake bleed screws.

**NOTE:**

The Retractor Bolts should be retained in the vehicle.

5. Once the retractor bolts are removed, apply and then release the driveline brake again – if the system has been sufficiently bled then the brake status light should be solid green with the brake released.
6. Ensure the diff rotates freely when the ABT™ Failsafe Emergency brake is released.
7. Attach 3 x taper plugs to the spring covers. Use Loctite Silver Grade Anti-seize on the threads of the taper plugs to assist with future removal. Torque to 10Nm.
8. Silicone may be used to fill the socket head of the taper plugs to prevent dirt ingress.
9. Attach 1 x pad wear indicator plunger to the EMMA™ piston inside the remaining hole in the spring cover. Torque to 15Nm.
10. Attach the pad wear indicator plug to the spring cover over the pad wear indicator plunger. Ensure it is threaded all the way onto the spring cover. Torque to 15Nm.
11. Attach the fibre washer and cap. Torque to 10Nm.

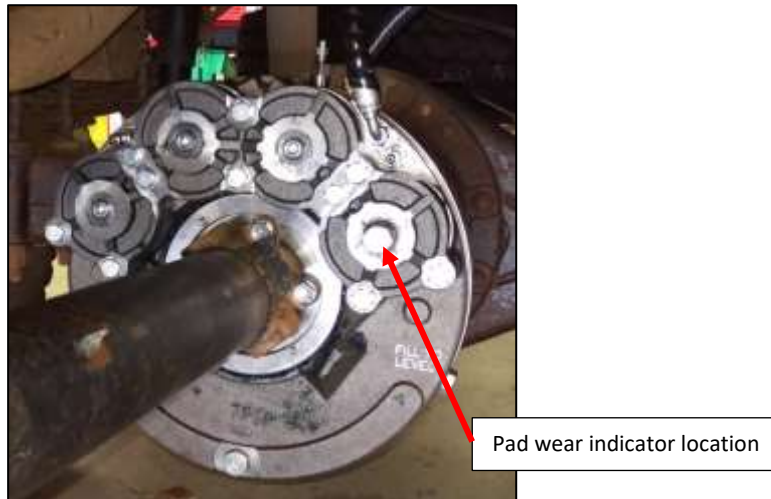

Figure 18: Brake assembly attached to rear diff centre.

12. Affix the ABT™ Failsafe caution label and ABT™ Failsafe Emergency warning label to the inside top corner of the windshield on the driver’s side.



Figure 19: Failsafe Emergency labels.



Figure 20: Failsafe Emergency labels on windshield.

13. Complete a vehicle pre-start check.
14. If the vehicle is to be used on public roads it will require approval for road use.
  - a. All vehicles can be fitted with an aftermarket modification plate.
  - b. Please contact ABT™ customer service for details regarding Failsafe Emergency equipped vehicles requiring approval.

## 16. Control System Setup

1. Ensure the battery is fully charged and in good working condition.
2. With the vehicle engine running, twist and release the red E-stop button to release the brakes - the system will automatically detect the correct brake release pressure during its first release.
3. Activate all connected interlocks and check function:
  - a. To activate the door interlock – open and close a vehicle door.
  - b. To activate the seat belt interlock – connect and disconnect the driver’s seatbelt.
  - c. To activate the stall interlock – switch the ignition off, wait for 5 seconds, then start the engine, run for 10 seconds and then switch the engine off again.
  - d. The corresponding warning light on the control unit should display when each interlock is activated (note: interlock warning lights are only displayed when ignition is on).
4. Set the HSI speed threshold:
  - a. After releasing the brake for the first time the green HSI light will begin flashing – this indicates the HSI speed threshold needs to be set.
  - b. The HSI system overrides the door, stall and seatbelt interlocks when the vehicle is travelling at speeds above the HSI threshold – this is designed to prevent unintended brake application at high speeds.
  - c. Start the engine, release the brakes and accelerate the vehicle up to the desired HSI threshold speed (On vehicle installations, ABT™ sets the HSI speed to 20km/h by default. This may be reset to suit the site-specific speed limit).
  - d. While maintaining this speed, press and hold the grey button on the control unit for 3 seconds – the control unit will beep twice to confirm the speed has been accepted.
  - e. If HSI is not required, simply complete the above procedure with the vehicle is stationary.



Figure 21: ABT™ Failsafe Emergency brake control unit warning lights



## 17. Service Schedule

The following table shows the recommended service intervals for ABT™ Failsafe Emergency brake systems fitted to vehicles being operated in a harsh mining environment. ABT™ recommends each site undertake a review of the service intervals and adjust to suit their specific conditions.

	Frequency
Pre-Start Check	Daily
Minor Service	Monthly or every 5,000 km or every 100 hours (whichever occurs first)
Major Service	When rear brake pad wear reaches minimum (as indicated by the pad wear indicator)

The pre-start check involves a quick check of the fluid levels and confirms proper brake system operation.

The minor service involves a general system inspection and replacement of the ABT™ “Blend 20” cooling fluid in the brake.

The major service involves a system inspection and replacement of any worn components to ensure continued reliable operation of the ABT™ Failsafe braking system.

## 18. Pre-Start Check

1. Check ABT™ Failsafe Emergency brake pump reservoir level. If low, top up with ATF Dexron III and check system for leaks.
2. With the doors closed, engine running and driver's seat belt connected, press the E-Stop button:
  - a. The brake status light on the ABT™ Failsafe Emergency control unit should be solid red.
  - b. The park brake should be applied.
3. Twist and release the E-Stop button:
  - a. The brake status light should flash red momentarily and then change to solid green.
  - b. The park brake should now be released.
4. Check the park/emergency brake applies when (Note: optional interlock connections c, d and e if connected):
  - a. The E-Stop is pressed.
  - b. The ignition is switched to the 'ACC' position.
  - c. The door is opened (door ajar warning light should display on control unit).
  - d. The driver seatbelt is released (seatbelt warning light should display on control unit).
  - e. The engine is stalled (low oil pressure warning light should display on control unit).
5. Carry out park brake performance test:
  - a. Ensure the test is carried out on a level surface, with no obstructions in front of the vehicle.
  - b. With engine running at normal operating temperature
    - Apply ABT™ Failsafe Emergency brake
    - Depress clutch
    - Engage third gear low range
    - Do not press footbrake
    - Do not rev engine (engine should be idling as normal)
    - Slowly release clutch
    - Allow the engine rpm to slowly reduce until either the engine stalls or the vehicle rolls forward
    - Vehicle must stall without the vehicle driving through the brake
6. If the vehicle drives through the brake a Major Service must be performed.

Note: The Pre-Start check does not replace visual inspection of the pad wear indicators.

## 19. Minor Service (100 hrs)

1. Check brake unit for leaks:
2. Check the fluid level in the ABT™ Failsafe Emergency pump reservoir. Top up if necessary.
3. Check ABT™ Failsafe Emergency pump for leaks:
  - a. Engine running
  - b. Twist and release the E-stop button to release the Failsafe Emergency brake
  - c. Release the brake for 30 seconds
  - d. The alarm should remain silent and the pump should not recharge
4. Check hydraulic lines for cracks or damage.
5. Check the breather hose for cracks or damage.
6. Check the expansion chamber filler breather cap is clear.
7. Check all electrical connectors and wiring for damage or corrosion.
8. Ensure the vehicle battery is in good working order.
9. Check brake pad wear:
  - a. Apply the ABT™ Failsafe Emergency driveline brake.
  - b. Remove the protective cap on the pad wear indicator (found on the spring cover).
  - c. The plunger should project out from the gland fitting.
  - d. The distance the plunger projects shows the remaining brake pad wear available. (New pads = 2mm approx.).
  - e. Refit the protective cap and fibre washer.

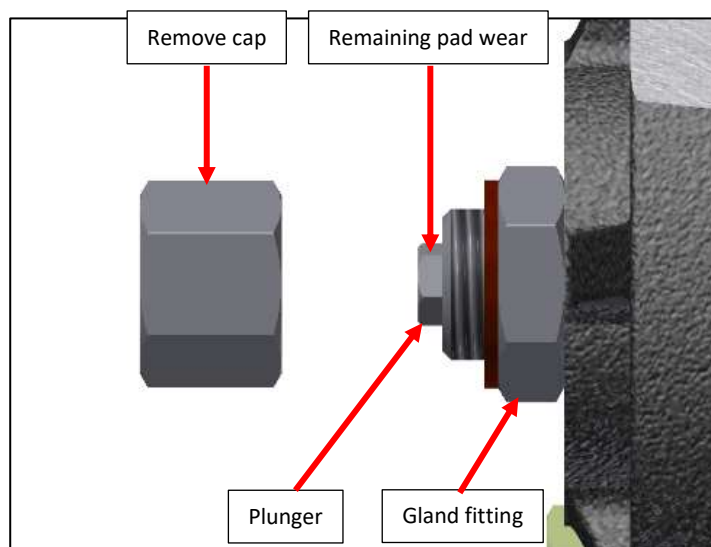

Figure 22: Rear pad wear indicator schematic.

10. If the brake pads have worn beyond the wear limit, then a major service must be completed.
11. Remove 3x tapered plugs, recoat each one with anti-seize and refit them. Silicon should be placed in the hex socket to aid future removal.
12. Drain and discard the ABT™ “Blend 20” cooling fluid from the driveline brake.

- 
- a. At least 800 ml of ABT™ “Blend 20” cooling fluid should be found in the brake. Check for leaks if this amount is not found.
  - b. The cooling fluid should drain freely from the brake. If it comes out in a “glug, glug” fashion ensure there is no blockage in the breather line.
  - c. Dispose of used ABT™ “Blend 20” cooling fluid responsibly in accordance with regulatory and environmental legislation.
13. Refit the drain plug with a new sealing washer.
  14. Refill the brake up to the level plug (fill to spill). Approximately 1 litre of ABT™ “Blend 20” cooling fluid is required.
  15. Conduct a “vehicle pre-start check”.

## 20. Major Service

1. Check ABT™ Failsafe Emergency driveline brake systems for leaks.
2. If leaks are present replace damaged seals where necessary during the major service (section 26).
3. Repair/replace damaged parts where necessary during the major service.
4. Test the EMMA springs and pistons (section 21).
5. Disassemble the brake (section 22).
6. Perform a rotor service (section 23).
7. Perform a pad change, seal change and housing service (section 24).
8. If the springs need to be replaced, perform a replacement now (section 25).
9. Assemble the brake (section 27).
10. Conduct a “vehicle pre-start check”.

## 21. EMMA Piston Test Procedure

1. Remove the 3x tapered plugs and 1x pad wear indicator from the spring cover. Refer to the exploded view for more details.
2. Operate the brake to check for fluid or washout. Any substances being ejected from the holes indicates a failed EMMA piston seal which will need to be replaced.
3. Fit 4x retractor bolts into the spring cover and torque to 80 Nm. Alternatively, while the system is released retract the pistons and wind in the retractor bolts in.
4. Loosen the retractor bolts until there is approximately 2mm gap to the spring cover.
5. A short test is required to check the integrity of the springs in the ABT™ Failsafe Emergency brake. Assistance is required for this test.
6. While the ABT™ Failsafe Emergency brake is applying/releasing observe the movement of the retractor bolts.
7. The 4x retractor bolts should move in and out simultaneously.
8. If the retractor bolts move simultaneously then the spring integrity check is complete.
9. If the retractor bolts appear to be moving unevenly then check the following:
  - a. While the brake is releasing (the pump is running) one or more bolts moves quickly out at the beginning of the pump cycle and is then followed by the remaining retractor bolts moving slowly as the pump cycle continues and then finishes.
  - b. While the brake is applying (fluid dumping back to reservoir) the slow-moving bolt/bolts from the previous test move back into the spring cover first and are then followed by the remaining bolt/bolts.
10. If the retractor bolts behave as explained in step 9 then the spring covers must be removed to visually check the springs.
11. With the brake released retighten the retractor bolts. Then apply the brake.

## 22. Service Disassembly Procedure

12. Remove the 3x tapered plugs and 1x pad wear indicator from the spring cover. Refer to the exploded view for more details.
13. Fit 4x retractor bolts into the spring cover and torque to 80 Nm. Alternatively, while the system is released retract the pistons and wind in the retractor bolts in.
14. Drain and discard the ABT™ “Blend 20” cooling fluid from the brake.
  - a. At least 800 mL of ABT™ “Blend 20” cooling fluid should be found in the brake. Check for leaks if this amount is not found.
  - b. The ABT™ “Blend 20” cooling fluid should drain freely from the brake. If it comes out in a “glug, glug” fashion ensure there is no blockage in the ABT™ Failsafe breather line.
  - c. Dispose of used ABT™ “Blend 20” cooling fluid responsibly in accordance with regulatory and environmental legislation.
15. Remove the drive shaft from the ABT™ yoke.
16. Disconnect the driveline brake hydraulic line from the brake.
17. Undo to pinion nut and remove from the pinion shaft.
18. Remove and discard the remaining 12x housing bolts.
19. Carefully separate the inner and outer housings until there is a slight gap between them.
20. Sit the outer housing assembly, yoke and rotor on a clean bench.

## 23. Rotor Replacement Procedure

1. Disassemble the outer housing according to section 22.
2. Remove the yoke and rotor from the assembly. Clean the rotor.
3. Inspect the rotor and yoke splines for wear.
4. Check for movement between the rotor and yoke. If there is excessive movement between the splines of the mating components the rotor should be replaced.
5. Inspect the rotor friction surface. If there are signs of scouring covering more than 50% of the surface the rotor should be replaced.

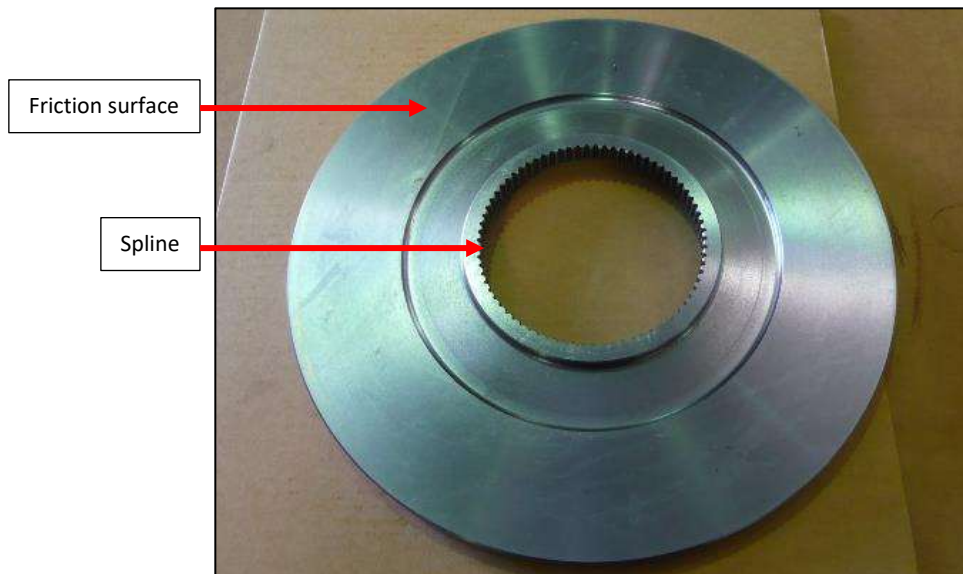

Figure 23: Rotor.

6. Measure the thickness of the friction surface using a micrometer at four evenly spaced position around the rotor. If thickness is below 14.0 mm the rotor should be replaced.



## 24. Pad Change, Seal Change and Housing Inspection

1. Disassemble the outer housing according to section 22.
2. Remove and discard the inner and outer brake pads.
3. Inspect the diff pinion seal. Replace if showing any signs of damage or leaking.
4. Remove the housing O-ring from the inner housing and discard.
5. Clean the inner housing and inspect for damage or wear.
6. If the springs or EMMA piston seals need to be replaced, do so now (section 25, 26).
7. Install a new O-ring onto the inner housing.
8. Install the inner brake pads in the inner housing ensuring correct orientation.



Figure 24: Brake pad positions

9. Remove the cassette seal from the outer housing and discard.
10. Clean the outer housing and inspect for damage or wear.
11. Install a new cassette seal into the outer housing.
12. Install the v-seal cover to the yoke.
13. Install a new v-seal onto the yoke.
14. Install the outer housing assembly onto the yoke.
15. Install the rotor onto the yoke spline ensuring correct orientation.
16. Inspect all fittings for damage or corrosion and replace if necessary.

## 25. Spring Replacement Procedure

1. Disassemble the outer housing according to section 22.
2. Remove the 10x spring cover bolts and discard.
3. Loosen the 4x retractor bolts progressively and in sequence no more than 3x full turns at a time until completely removed. Retain the retractor bolts for later use.
4. Remove the spring cover.
5. Remove and discard spring cover gaskets.
6. Remove the disc springs and inspect each one for signs of excessive wear or cracking. If there are any cracked springs, then all 24x springs must be replaced.
7. If there are no cracked springs clean all thoroughly.
8. Perform an EMMA piston seal replacement now. (Section 26).
9. Lubricate all disc springs with a high-pressure grease (Castrol LMM recommended) and reinstall on the park/emergency pistons. There is 6x springs per piston stacked in series.



Figure 25: Disc springs installed on Failsafe Emergency brake piston.

10. Install new spring cover gasket and refit spring cover.
11. Install 10x spring cover bolts and washers finger-tight.
12. Reinstall the retractor bolts and torque to 80Nm.
13. Install and torque all spring cover bolts progressively and in sequence (one full turn at a time) to ensure that the spring cover does not distort or crack, torque to 60 Nm. Ensure each bolt is torqued twice.

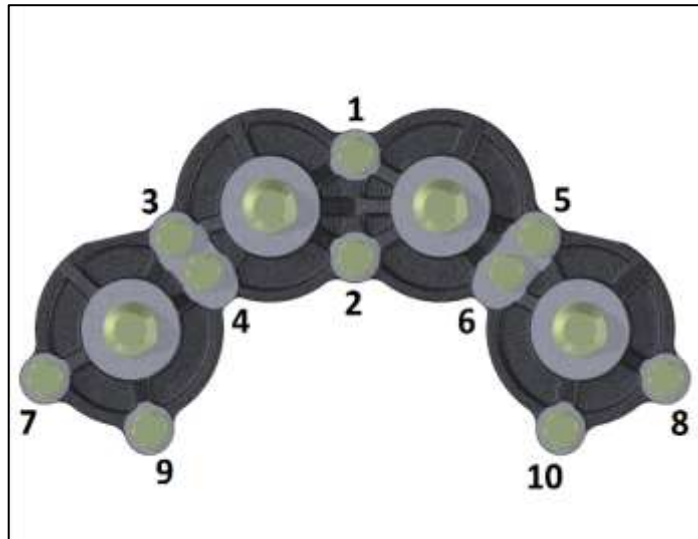

Figure 26: Spring cover bolt torque sequence.

## 26. EMMA Piston and Piston Seal Replacement Procedure

1. Follow steps 1-7 in section 25 to remove piston cover and springs.
2. Remove the pistons from the bore. A slide hammer may assist in removal.
3. Remove the piston O-ring seals and backup rings.
4. Clean the pistons with parts cleaner.
5. Inspect the pistons for damage, if there are signs of pitting and corrosion in the O-ring grooves the pistons should be replaced.
6. Apply a light smear of silicone grease to the pistons where the O-ring is seated (Parker Super O Lube recommended).
7. Attach the piston seals to the pistons. Ensure the O-rings and back-up washers are installed in the correct position and not twisted.

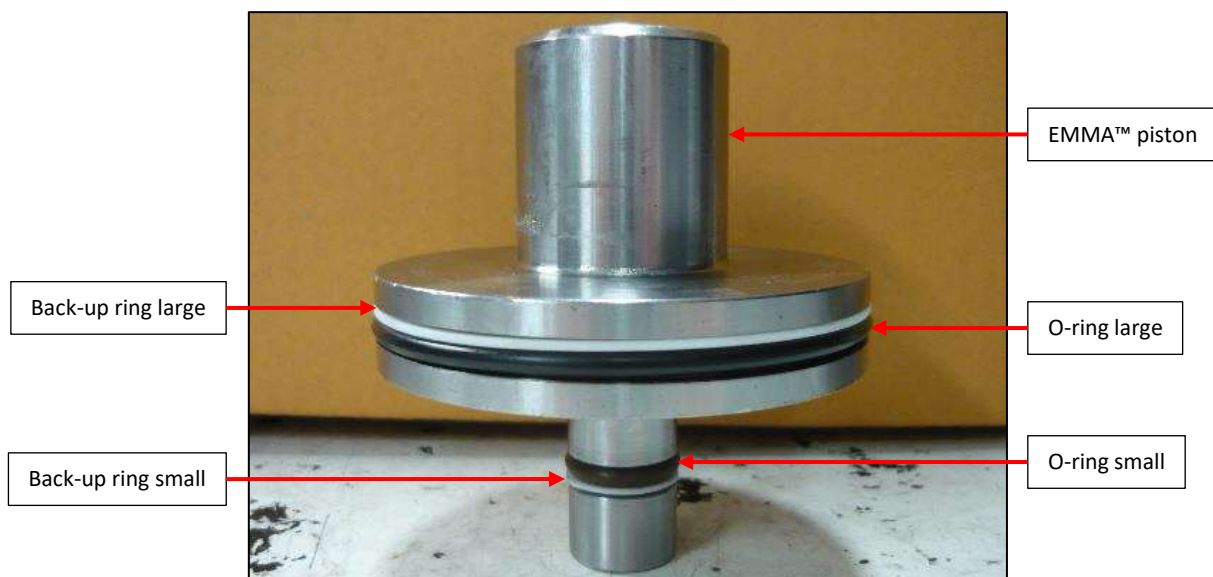

Figure 27: EMMA piston with seals installed.

8. Clean the exposed areas of the Failsafe Emergency pistons in cases where the pistons have not been removed.
9. Ensure the piston seals avoid contamination during cleaning process.
10. Clean the outer housing and spring cover. Inspect both for damage.
11. Wipe the piston bores dry and apply a small amount of silicone grease in the piston bore.
12. Install any pistons that were previously removed.
13. Follow steps 9-13 in section 25 to reassemble piston springs and spring covers.

## 27. Service Assembly and Bleed Procedure

1. Using a suitable lifting apparatus fit the ABT™ Failsafe Emergency brake unit over the pinion shaft.
2. Hold the brake rotor to prevent it from detaching from the yoke during assembly.
3. Lift outer assembly and align the yoke with the pinion shaft with the EMMA™ spring covers positioned towards the bottom of the brake.
4. Once the brake is held by the pinion shaft, rotate the outer housing until the EMMA™ spring covers are positioned towards the top of the brake.

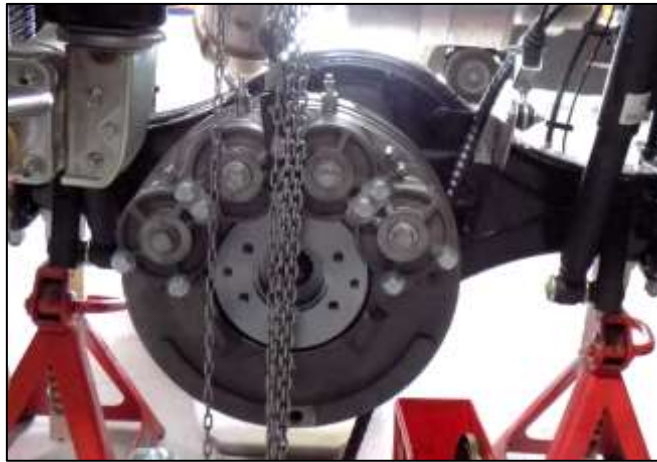

Figure 28: Brake in place

5. Fit the 12x M10 bolts and torque to 50 Nm in a star sequence. Ensure each bolt is torqued twice.

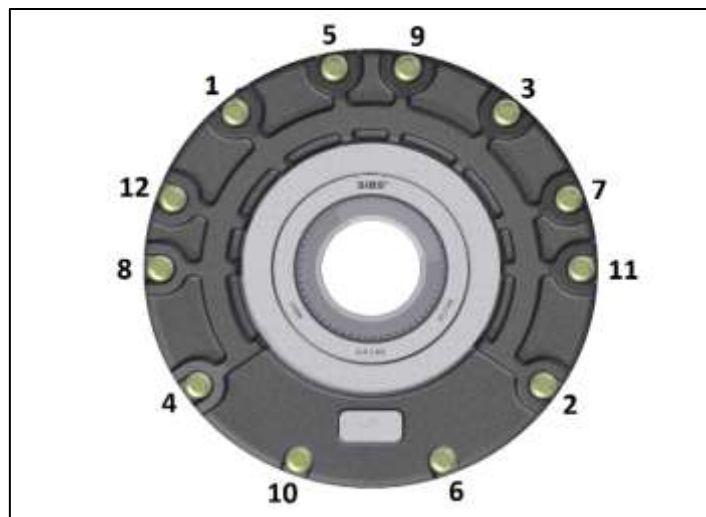

Figure 29: Housing bolt torque sequence.

6. Attach the pinion shaft nut and washer. Torque to Fuso Canter specifications.
7. Ensure the diff rotates freely when the ABT™ Failsafe Emergency brake is released.
8. Assemble the drive shaft onto the ABT™ yoke and align the 4x mounting holes.
9. Apply Loctite 262 to the threads on the short end of the 4x drive studs. Torque drive studs to 100 Nm.
10. Attach 4x washers and nuts to the drive studs. Torque nuts to 130 Nm.



Figure 30: Installed brake

11. Fill the cavity behind the V-lip seal with a high temperature bearing grease (Castrol LMX recommended) via the grease nipple located on the yoke. Do not over-grease the V-lip cavity.
12. Remove the 4x retractor bolts from the spring cover.
13. Fit the pad wear indicator to the lowest piston:
  - a. Screw the pad wear indicator plunger into the lowest piston thread and torque to 15 Nm.
  - b. Apply Loctite 222 to the gland fitting on the thread that attaches to the spring cover only.
  - c. Fit the gland fitting over the piston and screw this into the spring cover. Torque to 15Nm.
  - d. Fit the stainless steel protective cap and fibre washer to the gland fitting.

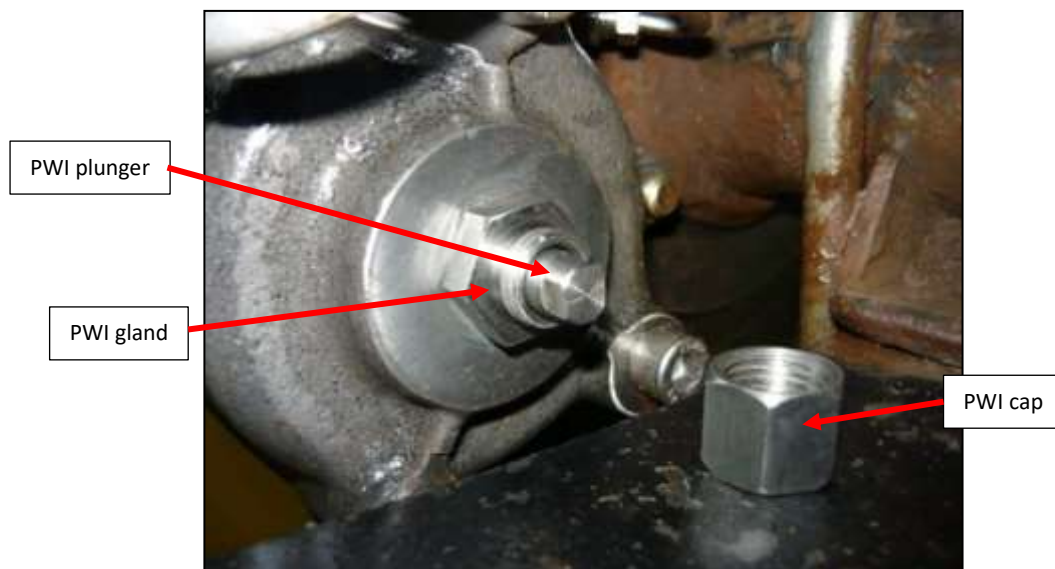

Figure 31: Pad wear indicator install in spring cover.

- e. Fit 3x supplied tapered plugs to seal the remaining holes in the spring cover. Use an anti-seize or a low strength thread locker on the threads to prevent the plugs seizing in the spring cover. The hex sockets may be filled with silicone or similar, to aid future removal.
14. Remove the ABT™ “Blend 20” cooling fluid fill plug.
15. Fill the ABT™ Failsafe brake unit with new ABT™ “Blend 20” cooling fluid and refit the fill plug with a new copper washer. Approximately 1000ml of ABT™ “Blend 20” cooling fluid is required.

16. Check the differential oil level and top up if necessary.
17. Inspect all the driveline brake hydraulic hoses and replace as required.
18. Replace all breather hoses.
19. Flush the pump reservoir with new ATF Dexron III and then fill to level window.
20. Prime the ABT™ Failsafe emergency brake pump by running intermittently (no more than 10 seconds at a time) until full hydraulic pressure is reached and the motor stops running automatically.
  - a. To run the pump and release the EMMA™ brake, twist the red pushbutton on the control unit clockwise.
  - b. To release hydraulic pressure and engage the EMMA™ brake, press the red operator pushbutton.
  - c. While performing this priming process, ensure the EMMA™ reservoir is constantly topped up to prevent the pump from running dry.
21. Bleed the driveline brake system as per the installation instructions.
22. Check that there are no leaks from the system.

## 28. Troubleshooting

1. Problem
  - a. Possible cause
    - i. Solution
  
2. Fault light on control unit flashing.
  - a. 2x flashes then rest – low battery fault (below 11V (below 22V on a 24V system))
    - i. Charge vehicle battery
    - ii. Fault will self-clear when battery voltage is above 11V (22V)
  - b. 3x flashes then rest – control unit PCB too hot
    - i. Remove any sources of heat that could be causing the control unit to overheat
    - ii. Fault will self-clear when the PCB temperature drops below a certain level.
  - c. 4x flashes then rest – Failsafe Emergency brake took too long to release – operation aborted.
    - i. Check pump reservoir level is not too low. If low check system for leaks.
    - ii. Possible air in system causing slow release. Bleed Failsafe Emergency brake system.
    - iii. Pump motor has is too hot and has lost effectiveness – allow to cool to ambient.
    - iv. Cycle ignition to clear the fault from the control unit.
  - d. 5x flashes then rest – pump relay fault
    - i. Ensure wiring is not causing a short or open circuit to pump relay.
    - ii. Check pump relay for correct function – replace if required.
    - iii. Cycle ignition to clear the fault from the control unit.
  - e. 6x flashes then rest – dump valve fault
    - i. Ensure wiring is not causing a short or open circuit to dump valve.
    - ii. Check dump valve for correct function – replace if required.
    - iii. Cycle ignition to clear the fault from the control unit.
  - f. 7x flashes then rest – diff lock solenoid fault
    - i. Check vehicle diff lock is functioning correctly.
    - ii. Check wiring connections to diff lock switch.
    - iii. Check ABT™ Failsafe Emergency diff lock relay.
    - iv. Cycle ignition to clear the fault from the control unit.
  - g. 8x flashes then rest – pressure sensor fault
    - i. Ensure wiring is not causing a short or open circuit to pressure sensor.
    - ii. Check pressure sensor for correct function – replace if required.
    - iii. Cycle ignition to clear the fault from the control unit.



3. ATF warning light on control unit on.
  - a. Vehicle parked on steep incline causing sensor to read incorrect fluid level.
    - i. Park vehicle on flat surface and check ATF warning light if off.
  - b. Low fluid level in ABT™ Failsafe Emergency brake pump reservoir.
    - i. Top up reservoir with ATF Dexron III and check system for leaks.
4. Brake status LED is solid green and control unit is not responding.
  - a. Control unit is in 'Failsafe version 3' mode.
    - i. Conduct a master reset of the control unit by holding the manual release button and cycling the E-stop button 3 times within 5 seconds. All lights on the control unit will flash once to confirm reset was successful and all settings have been cleared.
5. Brakes drag/brakes not fully releasing after operation.
  - a. Control unit may have learned the incorrect release pressure (retractor bolts left in place during initial set-up).
    - i. Perform a master reset of the control unit.
  - b. EMMA™ piston seals bypassing or seals contaminated & swollen preventing them from retracting.
    - i. Inspect brake for ATF leakage around rear of spring cover.
    - ii. Strip brake, inspect components. Replace seals as required.
  - c. Insufficient hydraulic pressure to release EMMA™ brake.
    - i. Place vehicle on hoist if required and release EMMA™ brake.
    - ii. Carryout pressure check in EMMA™ circuit should be 850psi approx., if pressure is insufficient change pressure switch. If pressure still low, EMMA™ pump may be at fault.
    - iii. Strip brake & inspect.
6. Brake not releasing/partially releasing after operation (brake status light flashes green or red)
  - a. The return gallery in the pump manifold may be blocked and is holding residual low pressure in the line.
    - i. Carefully open one of the EMMA™ hydraulic hose fittings to release any pressure. If pressure is released continue to step ii.

**WARNING:**

The hydraulic hose contains fluid under pressure. Ensure adequate precautions are taken when opening the hydraulic fitting.

- ii. Remove the orifice plug (18-9037) from the manifold block and clean.
7. ABT™ Failsafe Emergency brake applies unexpectedly.
  - a. Faulty wiring causing intermittent loss of continuity.
    - i. Inspect/test 12 volt (or 24 volt) ignition switched & 12 volt (or 24 volt) constant supply. Ensure all connections are clean, secure and free of corrosion.
    - ii. Check door switches.
    - iii. Check seatbelt switches.
    - iv. Check oil-pressure switches.

8. ABT™ Failsafe Emergency brake is poor. Brake not holding on inclines.
  - a. Brake pads and/or rotor worn.
    - i. Check pad wear indicators. If pads below wear limit conduct a major service.
9. ABT™ Failsafe Emergency brake slow to apply
  - a. Brake pads worn.
    - i. Check pad wear indicators. If pads below wear limit conduct a major service.
  - b. ABT™ Failsafe Emergency relief valve set too high.
    - i. Adjust to desired application speed by loosening locknut and turning adjusting screw out. Adjust ½ turn at a time & test.
10. ABT™ Failsafe Emergency brake pump runs intermittently during service (brake status light flashes red and beeps occasionally).
  - a. Minor leak in Failsafe Emergency brake system
    - i. Check all hydraulic hoses and connections for signs of leaking ATF.
    - ii. Strip brake and check Failsafe Emergency brake piston seals and bores. Replace as required.
11. Pump does not run (ABT™ Failsafe Emergency brake does not release).
  - a. Check interlocks are not preventing brake release
    - i. Close all doors, fasten driver's seatbelt, start vehicle engine.
  - b. Loss of power to ABT™ Failsafe Emergency control unit (indicated by lack of brake status LED).
    - i. Check all fuses. If blown identify cause and repair.
  - c. Loss of power to ABT™ Failsafe Emergency brake pump.
    - i. Check all fuses. If blown identify cause and repair.
    - ii. Check function of relay mounted at vehicle battery. Replace if required.
    - iii. Check for continuity of wiring from battery to pump motor and relay to control unit.
  - d. Faulty pump motor.
    - i. Replace pump motor.